

Recommendations for storage of wood pellets

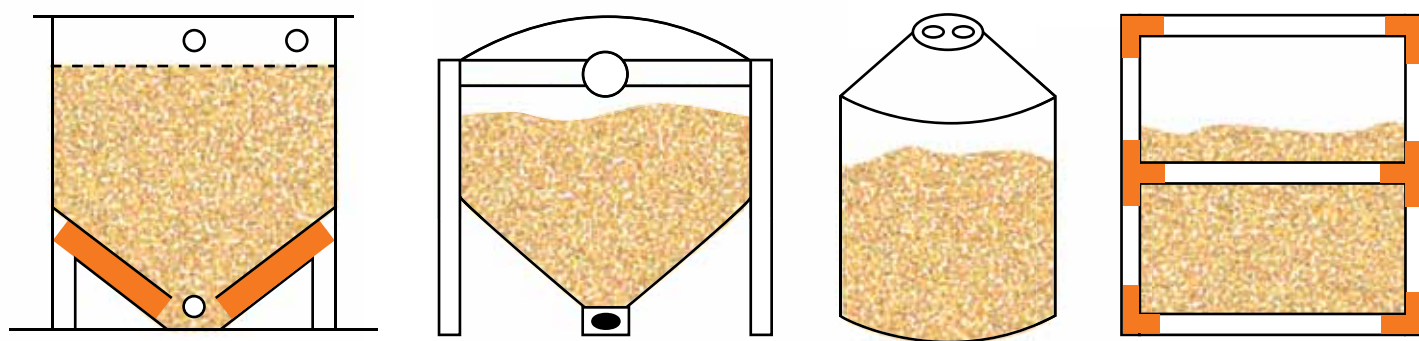

Recommendations for storage of wood pellets

Deutscher Energieholz- und Pellet-Verband e.V. (DEPV) (German Wood Fuel and Pellet Association)

Reinhardtstr.18
10117 Berlin
Germany
Tel.: 0049 (0)30 688159966
Fax: 0049 (0)30 688159977

info@depv.de
www.depv.de

Deutsches Pelletinstitut GmbH (German Pellet Institute)

Reinhardtstr.18
D-10117 Berlin
Tel.: 0049 (0)30 688159955
Fax: 0049 (0)30 688159977

info@depi.de
www.depi.de

Translated by Pieter D. Kofman, senior consultant wood for energy, on behalf of the Irish Department of Agriculture, Fisheries and Food with the permission of DEPV.

The UK Pellet Council wishes to thank DEPV for allowing the use of this guide, and COFORD for allowing the use of the English Version.

The brochure *Recommendations for storage of wood pellets*, including annexes, and this translation is protected by copyright. Any use outside of copyright laws without the direct consent of DEPV is illegal. This is particularly valid for multiplication, translations, microfilm copying and publishing on electronic media such as the internet.

© Deutscher Energieholz- und Pellet-Verband e.V. (DEPV) 2012

Please send comments and suggestions for improvement to the address above

We are grateful to Fachagentur Nachwachsende Rohstoffe (FNR) for support of the cooperation project with the University of Göttingen Environmental friendly production and storage of wood pellets. Important results from this project have been included in this brochure.

CONTENTS

1. On this Information brochure	1
1.1 Intended use of this brochure	1
1.2 Intended audience	1
1.3 Normative references	1
2. For your safety	2
3. Certified Fuel	3
4. Storage of wood pellets	4
4.1 Location of the storage room	4
4.2 Accessibility of pellet storage silo	4
4.3 Filling operation	4
5. Purpose-built storage facilities	6
5.1 General	6
5.2 Requirements for purpose-built systems	6
5.2.1 Coordination between boiler and silo suppliers	6
5.2.2 Distance from walls and ceiling	6
5.2.3 Connection to the filling pipe	6
5.2.4 Release of the pellet transport air	6
5.2.5 Installation in the silo room of a purpose-built storage system	6
5.2.6 Follow mounting and installation manuals	7
5.2.7 Filling instructions	7
5.2.8 The heating appliance should be switched off during filling	7
5.2.9 Requirements for the assembly	7
5.2.10 Purpose-built silos outside the building	7
6. Construction examples of purpose-built silo systems	8
6.1 Aboveground mounting	8
6.1.1 Purpose-built silos made of flexible fabric with flat bottom	8
6.1.2 Conical silo	8
6.1.3 Trough silo	9
6.1.4 Elevating silo	9
6.2 Silos for below-ground storage	9
6.3 Examples of storage systems	11
7. Homemade pellet storage	12
7.1 The size of the storage room	12
7.2 Protection from moisture and water	12
7.3 Static pressure	12
7.4 Ground plan of a pellet store	13
7.5 Cross section of a silo with inclined bottom	13
7.6 Construction recommendations for the inclined bottom solution	14
7.7 Cross section of a pellet silo	15
7.7.1 Room length less than 2 m	15
7.7.2 Room lengths from 2-5 m	15
7.7.3 Room lengths greater than 5 m	16
7.8 Function of the impact protection mat	16

7.9 Doors, windows and hatches	17
7.10 Installations in the storage room	17
7.11 The filling system	18
7.11.1 Inblow and exhaust pipes	18
7.11.2 Design of the filling system	18
7.12 Special solutions for the filling system	19
8. Construction examples of pellet silos	21
8.1 Pellet silo with inclined bottom and screw conveyor	21
8.2 Pellet silo with inclined bottom and suction extraction	21
8.3 Pellet silo without inclined bottom and screw conveyor	22
8.4 Pellet silo without inclined bottom and suction extraction	22
9. Measuring systems for pellet silos	23
9.1 Silo fill level	23
9.2 Filling status with pressure sensors	23
10. Fire protection measures at the silo	24
11. Annex	26

1. ON THIS INFORMATION BROCHURE

1.1 INTENDED USE OF THIS BROCHURE

This brochure is the result of voluntary work carried out by members of Deutschen Energieholz- und Pellet-Verbandes e.V., the German Wood Fuel and Pellet Association (DEPV). It is the third edition edited by Deutsche Pelletinstitut GmbH.

Anyone may use this brochure free-of-charge. It is an important, but not the sole source of information on pellet storage. By applying the knowledge contained in this brochure, no-one is relieved of responsibility for their actions or for the correct application in each case.

The brochure contains requirements for the construction of pellet storage facilities and storage in basements. It does not replace any instructions from the companies that produce these systems. Planning aids and instructions of the producers of internal handling systems need to be followed.

This document is aimed at the private builder. Possibilities for commercial exploitation are only given as examples. It provides information on:

- Safety
- Fire protection
- Static requirements
- Equipment used in pellet storage
- Examples of equipment
- Ready-built storage systems.

1.2 INTENDED AUDIENCE

This information brochure is aimed at private persons and professional groups, who want to establish a pellet storage facility. The relevant national building codes and regulations concerning the use of heating appliances should be followed.

1.3 NORMATIVE REFERENCES

- ÖNORM M 7137: Wood pellets - Requirements for storage of pellets at the ultimate consumer
- EN 303-5 Heating boilers. Heating boilers with forced draught burners. Heating boilers for solid fuels, hand and automatically fired, nominal heat output of up to 500 kW.
- DIN 51731 Testing of solid fuels - Compressed untreated wood - Requirements and testing
- EN 14961-2 Solid biofuels — Fuel specifications and classes — Part 2: Wood pellets for non-industrial use
- ENplus-certification system
- National fire prevention codes.
- VDI-Richtlinie 3646, probably valid from end 2012.

2. FOR YOUR SAFETY

For all fuels safety rules governing handling, heating with that fuel and storage apply. The same applies when using wood pellets. Please take these recommendations seriously and consider them regularly.

Switch off the pellet boiler in good time before filling the storage room or the hopper or before working in the pellet storage area. Please consider the instructions of the boiler manufacturer. In general the boiler should be switched off at least one hour before filling the storage installation.

The storage space for wood pellets is not a place where people stay or move about, except where their presence is needed for the proper operation of the facility. Before the storage space is entered, it should be sufficiently ventilated by opening the door.

Purpose-built storage facilities made of fabric do not need additional ventilation, since these facilities usually are made of material which can breathe and as such can guarantee an exchange of air.

In closed systems, the use of special ventilation caps on the inblow and exhaust pipes is recommended. These caps allow the exchange of air between inside and outside (see Plate 18) the storage installation. They effectively prevent emissions and odours from pellets that have been blown into the silo. The caps are designed in such a way that moisture cannot enter the storage space. Changing old closed caps with ventilation caps is recommended. The caps can be ordered from suppliers of heating systems.

Unauthorized persons should not enter the storage space or children use it as a play area. Moving parts, such as augers, are in principle dangerous and can cause harm if not properly handled or maintained. Pellet storage facilities should only be entered for reasons connected to the operation of the heating installation, such as installation or maintenance.

Normally, burning fuel for room heating does not pose a risk. In case of unforeseen malfunctions of boilers or storage facilities there is a risk of elevated levels of dangerous flue gasses in the air (such as carbon monoxide) in all boiler and storage places that are enclosed. These gasses can accumulate over time and pose a risk. Even though there is no danger for the user of these installations, this risk cannot be excluded. In storage facilities made of fabric, the danger is diminished because of the possibility of air exchange.

Together with HSE the UKPC has produced the following safety recommendations:

Safety recommendations for pellet storage facilities which can contain less than 10 tonne:

- Each pellet storage facility should have at least two ventilating connector caps (filling and exhaust connector) with each having a free air flow surface area of at least 20 cm² to ventilate the storage space.
- No personnel should enter the hopper/tank unless fully trained and competent in confined space entry procedures.
- Ensure that the boiler and pellet feed mechanism etc. is cleaned and serviced by a competent person as specified by the manufacturers' instructions.
- Before entering the storage space, the boiler and the fuel transportation system should be switched off and the door to the storage space should be fully opened at least a quarter of an hour beforehand.
- The filling and exhaust connector should be earthed with a copper earth wire with a cross section area of at least 4 mm².
- When cleaning the pellet storage space of pellet dust a dust mask should be worn.
- All pellet transport equipment and electric equipment should regularly be cleaned of pellet dust.
- The degree of filling should be checked through a sealed window (inspection porthole).

Warning sign

For the utmost safety of the consumer, the UKPC advises to place a warning sticker at the pellet store. There is an example in the Annex.

3. CERTIFIED FUEL

Fuel quality is decisive for the functioning of the pellet boiler. For use in private households it is recommended to use only certified quality pellets. We recommend that only wood pellets are bought that have been certified by ENplus, WFQA or DINplus.

Important quality criteria, such as a low ash and fines content as well as a high ash melting point are essential for an uninterrupted use of the boiler.

To this end the “Solid Biofuel Technical Committee 335” of the European standards organisation CEN has written a quality standard for wood pellets called EN14961-2 Solid biofuels - Fuel specifications and classes - Part 2: Wood pellets for non-industrial use. A quality assurance standard for these high quality wood pellets is almost ready for publication.

At the moment, this new European quality standard is implemented in Europe (Germany, Austria, Spain, Italy and Switzerland) by ENplus and in Ireland by WFQA. The ENplus certification requires the most stringent quality standards.

The systems take their basis in the mentioned European standard (which by the way is in the process of being transformed into a world wide ISO standard).

In principle these Quality Assurance systems certify that the pellets produced in a certain facility are equal to the demands of the European standard. The ENplus certification not only provides quality standards for the product but also for the trade. Due to the high demands on product quality and the quality assurance in trade, a high pellet quality can be ensured to the final customers. Only when the entire supply chain is certified to EN plus, the wood pellet quality can be guaranteed formally.

For use in private households it is recommended to use only certified ENplus A1 or WFQA A1 quality pellets. Quality class ENplus A2 and WFQA A2 are used in larger boilers in excess of 100 kW. It differs from A1 by the ash content and the ash melting behaviour (which is a required measurement in ENplus, but not in the EN standard). Also, the range of base materials for the production of these pellets is wider than for class ENplus A1. The boiler manufacturer must permit the use of the A2 quality pellets in their boilers.

ENplus A1 and WFQA A1 pellets contain a maximum of 1% fines when they leave the last place of loading. During blowing in of pellets into the storage area can the development of fines does not prevent, however, be greatly reduced. The development of fines is depending on the length of hosepipe between the truck and building, the number of bends in the supply line and other local circumstances. Fines generated in this process and by breakage of pellets will tend to accumulate in the lower region of the pellet store. To enable optimal functioning of the boiler and the internal handling system, the amount of fines has to be visually checked at the end of each heating season. Every second year or after every two to three fillings of the silo, it should be completely emptied and the fines removed from the storage space, preferably in spring or summer.

Wood pellets are an ecologically sound fuel and which do not involve any primary health risks. They can however lead to odours, which depend on the raw material that has been used in their production, especially the level of tannins and resins. During pellet pressing, these substances are activated and become volatile. The smell normally disappears within a few weeks. If it is rather strong, it is recommended that a ventilator is installed on the exhaust connector which can draw air through the silo. The ventilator may only be used when the boiler has been switched off.

Producers and suppliers of high quality wood pellets according to ENplus as well as more information can be found at www.pelletcouncil.eu.

For producers of WFQA certified wood pellets see www.wfqa.org.

4. STORAGE OF WOOD PELLETS

Wood pellets should be stored in specially-designed, purpose-built silos or in special storage rooms.

4.1. LOCATION OF THE STORAGE ROOM

Wood pellets are normally delivered by silo truck and blown into the silo. The silo truck should have the possibility to park close to the connectors. A long transport hose will cause mechanical wear on the pellets which will lead to additional fines.

If the inblow distance and the height differences are large between the pellet truck and the silo, special care must be taken with the internal piping between the connector and the silo with as few bends as possible.

The combined length of the hosepipe and internal piping should not exceed 30 m during filling of the silo. If longer distances have to be bridged, the pellet supplier should be consulted to see what technical solutions can be provided.

Every additional metre length of hose and every curve produce additional fines during the inblow process. The durability of wood pellets, which are produced from a naturally variable raw material, varies within the limits of the standard and the quality class of ENplus or WFQA. To summarise, the amount of fines arising during silo filling can vary with the length of the inblow hose and the number of curves (see Plate 1).

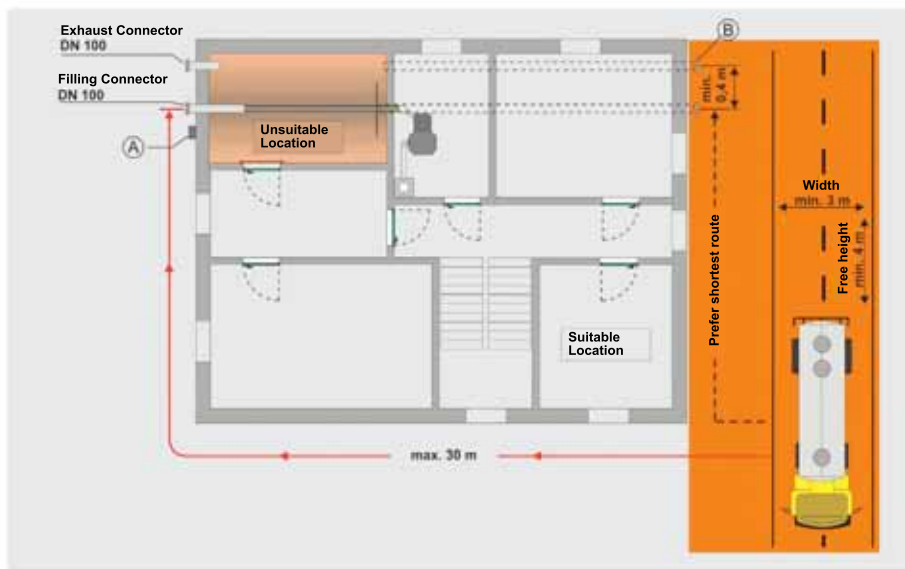

A: Power outlet 230 V 16A for the exhaust ventilator of the pellet supplier and/or disconnection switch for the pellet boiler.

B: Eventually a different placement of the filling pipe inside the building can considerably reduce the length of the filling hose.

Plate 1: Placement and accessibility of the storage room.

4.2 ACCESSIBILITY OF PELLET STORAGE SILO

The road to the silo must be suitable for silo trucks. This normally means that the access road should be 3 m wide with a free height of 4 m. The turning radius and the loading capacity of the truck should be considered. Also the time some streets may be blocked by the delivery should be taken into account.

If possible, the silo should be located behind an outer wall, since the inblow and exhaust connectors should preferably end in the open air and not inside a building. If the connectors cannot be installed in an outer wall, they should be located within two metres of the opening (cellar window or door), so that the exhaust ventilator can be connected outside the building to the ventilator and dust filter. In any case sufficient space must be reserved so that the filling hose can be connected.

Care should be taken that the filling hose does not snap off at the connector because of too acute an angle. The connectors should not be located higher than shoulder height. If this is not possible, a podium or ramp should be provided to allow safe access to the connectors.

The silo and the connectors have to be easily accessible to the truck driver. If a purpose-built silo has been installed, it should be easily accessible as well. Visual checks before and during the filling operation should be possible (see Plate 1).

4.3 FILLING OPERATION

Normally a purpose-built truck for the supply of wood pellets will deliver the goods. The truck can be equipped with an on-board weighing system, and normally carries filling hoses with an internal coating to reduce the wear on the pellets, as well as an exhaust ventilator with filter bag. The truck is equipped with a compressor that provides the air for blowing in the pellets.

Air delivery is comprises two components:

- pressure that is built up in the tank and the hose
- the air which propels the pellets through the filling hose.

The air pressure produced by the compressor is partly fed into the tank of the truck and pushes the pellets from the tank into the filling hose. The pressure in the tank can be read on a manometer on the truck. The remaining air is used to propel the pellets through the hose.

At short inblow distances it can be useful to have a higher pressure in the tank and only a small amount of transport air, while at longer transport distances the amount of transport air should be increased. The driver should decide which combination of transport air and pressure to use.

The exhaust ventilator minimizes overpressure in the silo. The blown-in transport air is sucked out of the silo and a slight under pressure is established and maintained in the silo. If there are leaks in the silo, this under pressure cannot be established and transport air with fine dust will enter the surrounding areas. A dustproof storage room is thus recommended.

For the exhaust ventilator a socket with 230 V with a 16A fuse is required close to the connectors.

5. PURPOSE-BUILT STORAGE FACILITIES

5.1. GENERAL

Requirements for wood pellet quality and safety of storage have clearly increased over the last few years and are better addressed by purpose-built storage systems than by home-built solutions.

Since there are many factors that influence the quality of stored wood pellets and the safety of the user, DEPV advises to use purpose-built pellet storage facilities that have been constructed for that purpose. These complete systems usually contain, in addition to the storage function, filling equipment and, at some installations, extraction equipment also. These purpose-built systems considerably reduce the amount of planning and construction effort compared with home-built solutions; producers of purpose-built systems should test for static strength as well as dust proofing during manufacture.

According to local conditions, the user will decide whether to construct a silo system or chose a purpose-built silo. Points to consider are annual fuel consumption, accessibility, the free height in the storage room and the condition of the floor. Purpose-built systems are generally the same cost as home-made solutions. They can be installed in cellars, but also in garages, carports or tool sheds, as long as the pellets can be easily delivered from there to the boiler. The following chapter presents an overview of different possibilities.

5.2 REQUIREMENTS FOR PURPOSE-BUILT SYSTEMS

5.2.1 COORDINATION BETWEEN BOILER AND SILO SUPPLIERS

One should ask the supplier of a purpose-built silo (installer or silo supplier) whether the equipment is compatible with the extraction equipment and/or with the boiler (for example the boiler manufacturer should approve the silo system). If there is no acceptance from the boiler manufacturer, then the responsibility should rest on the installer of the silo. This means that the installer of the complete heating systems guarantees the proper functioning of boiler, extraction unit and wood pellet silo.

5.2.2 DISTANCE FROM WALLS AND CEILING

Most storage systems need a minimum distance between the storage system and the enclosing surfaces (walls, ceiling and floor). These distances can vary according to the mounting instructions or the connectors.

The filling connectors should be easily accessible for the pellet supplier. The distance between the connectors and the wall should be at least a metre. The pellet supplier should not be forced to use curved connection pipes with a narrow radius between the hose and the filling connector of the silo.

5.2.3 CONNECTION TO THE FILLING PIPE

In pellet logistics, pipes, connectors and filling hoses with an internal diameter of 100 mm are mainly used. Nearly all purpose-built silos are offered with one or more filling connectors of type Storz A.

Whether an exhaust connector is required or not depends on the type of silo system (one should always follow the instructions of the silo producer). As stated, bends in the supply line will reduce the quality of the pellets and increase the amount of fines by wear. So already in the planning phase one should consider the direction of the filling pipe to avoid unnecessary bends or to reduce their number. Permanently installed pipes should be short (no longer than 10 m) and with few changes of direction. With changes of direction of more than 45 degrees, only curves with a radius of more than 200 mm should be used. Only metal piping should be used for the filling system to allow grounding of any build of electrostatic charge.

5.2.4 RELEASE OF THE PELLET TRANSPORT AIR

With silo systems that do not require evacuation of the transport air (see filling instructions of the producer), one should open doors or windows to let large amounts of air (up to 1400 m³/hr) escape, so that the pressure in the storage room is not increased. If an overflow opening is also installed, the free surface should at least be 170 cm².

If exhaust ventilation is required for the selected purpose-built storage system, then close to the exhaust connector a socket (230V, 16A) should be made accessible to the pellet supplier.

5.2.5 INSTALLATION IN THE SILO ROOM OF A PURPOSE-BUILT STORAGE SYSTEM

Storage systems that are inflated by transport air should be installed in such a way that they cannot be damaged by fixtures (lamps, piping etc).

Filling pipes should be earthed with a 4 mm² cable to the building's electric system (to be carried out by an authorised electrician). Earthing is necessary to discharge electrostatic charges that may occur during the filling.

If the filling piping is extended to the exterior of the building, it should be equipped with a ventilated cap, which allows the exchange of air between the pellet store and the outside air. In this way emissions and odours from the pellets are effectively prevented.

If piping crosses the path of the incoming pellets or the fabric of the silo comes between, an increased percentage of fines can be expected or the fabric can become damaged.

If the fabric comes in contact with lamps on the walls or the ceiling, it can become damaged by heat.

A fabric silo must be able to unfold itself completely. If folds occur, these can come in contact with the stream of incoming pellets and become damaged.

The position of the filling connector in a fabric silo must be chosen in such a way that the pellets only hit the reinforced part of the silo and do not damage any seams.

Because of the multitude of purpose-built silos, it should be signposted clearly on the storage silo if an exhaust ventilator has to be connected during the filling or not.

5.2.6 FOLLOW MOUNTING AND INSTALLATION MANUALS

It is imperative that purpose-built storage systems are assembled and used according to the producer's instructions. Please ask the installer to confirm that all parts have been installed and are being used according to the instructions of the producer.

5.2.7 FILLING INSTRUCTIONS

Since most storage systems are unique, each one should have its own filling instructions. These should be mounted in a spot close to the silo that is clearly visible for the supplier of the pellets.

5.2.8 THE HEATING APPLIANCE SHOULD BE SWITCHED OFF DURING FILLING

The pellet supplier should not deliver pellets unless the boiler has been switched off prior to the filling operation. The obligation to switch off the boiler rests on the owner of the installation. In the boiler producer's manual one can find how long before silo filling the boiler should be switched off.

5.2.9 REQUIREMENTS FOR THE ASSEMBLY

Purpose-built storage silo must be mounted on a firm floor. The floor should be level; if not, the unevenness should be corrected with suitable materials (such as a steel plate). The bearing capacity of the floor should be designed for point or area loads. Ask the producer of your silo for these requirements.

Normal relative air moisture content in the basement (50-80% RH) is not a problem for purpose-built silos, as long as air is circulated past the outer skin of the silo. The storage room should be ventilated when increased condensation is noticed. If the silo is made of fabric, it is important that the fabric does not touch any (cellar) walls since the pellets can absorb moisture from the wall. Moisture entry to the silo through the filling and exhaust connectors should be prevented in cases where they are ducted through an outer wall. Only connectors that are sufficiently tight should be used.

An opening should be present in the silo at normal reach height, that can eventually be used to fill pellets from sacks or can be used to clean the silo.

5.2.10 PURPOSE-BUILT SILOS OUTSIDE THE BUILDING

When a purpose-built silo is mounted outside the following should be considered:

Storage type	Static demands		Protection against UV radiation	Protection against precipitation	Connection to earth	Terrain demands
	Floor	Wind load				
Fabric silo	yes	yes	yes	yes	yes	Max 30 m hose
Above ground metal silo	yes	yes	no	no	yes	Max 30 m hose
Above ground fiberglass silo	yes	yes	no	no	yes	Max 30 m hose
Above ground plastic silo	yes	yes	depends	no	yes	Max 30 m hose
Above ground concrete silo	yes	yes	no	no	yes	Max 30 m hose

6. CONSTRUCTION EXAMPLES OF PURPOSE-BUILT SILO SYSTEMS

6.1 ABOVEGROUND MOUNTING

The most frequently used purpose-built systems are of the above-ground type which have a cladding of flexible polyester fabric, plastic or metal sheeting.

Purpose-built pellet silos should also be earthed. The construction materials should permit the discharge of electrostatic charge during filling. Depending on the construction, either the connectors or the entire system should be earthed.

Purpose-built systems are available [on the German market] in shapes and sizes that match the storage room (round, square, rectangular and in different heights). The movement of the pellets to the exit hole depends on the type of system: by funnel (common when the pellets are removed from the bottom by a screw conveyor) or through a moving withdrawal system from above (suction devices).

6.1.1 PURPOSE-BUILT SILOS MADE OF FLEXIBLE FABRIC WITH FLAT BOTTOM

The fabric construction is suspended from a frame made of steel or wood. Several different systems are available: square or rectangular in shape.



Plate 2: Silo with a wooden frame

Extraction system

In the silo systems outlined in this section pellets are extracted using a suction device from above, or through a disc agitator and a screw conveyor at the bottom. The silo can be entered at any time through an entrance opening (with translucent material) and be visually monitored. Flat bottom systems cannot be emptied totally; depending on the producer a rest volume of 5-15% remains (see manual).

6.1.2 CONICAL SILO

These silos look like an inverted pyramid. The extraction point is at the lowest point. This is also called a spot extraction system. It is recommended to have the possibility to close the system using a shutter that is shoved in between the silo and the system that moves the pellets to the boiler.



6.1.3 TROUGH SILO

Trough silos are a variation of the conical silo and have been optimized for volume, so they are usually rectangular. Extraction uses a screw conveyor. The pellets are delivered to a blowing system or moved directly to an intermediate storage silo (hopper) or boiler.



Plate 4: Trough silo

6.1.4 ELEVATING SILO

With this kind of silo, the bottom lowers to the ground at full load. When the silo is discharged the bottom is lifted again and forms the necessary funnel.



Plate 5: Elevating silo

Discharge system

In the silos outlined (6.1.2, 6.1.3 and 6.1.4) the pellets move by gravity to the discharge opening at the bottom. At the lowest point, the pellets are discharged either by a screw conveyor or by a suction device. Combinations are also possible.

6.2 SILOS FOR BELOW-GROUND STORAGE

Specification

Pellet silos that are buried below the ground have to comply with very special requirements. They should be absolutely water tight to prevent condensation build-up (due to variable air humidity levels), using either their location or technical solutions. They should be prevented from being suspended by groundwater, connected by piping to the boiler system, and it should be possible to empty the silo completely.

Discharge system

Discharge is solely using a suction system. Like other silo types, discharge can be carried out from the top or the bottom. Silos that are discharged at the bottom have a conical lower part. Pellets are discharged at the lowest point. The static pressure on the pellets is at its highest at this point, so they are stirred in the suction area. Depending on the manufacturer of the silo, this is done by rotary movement, vibration, return air or by stirring.

If discharge is from the top a motorized suction head is used or a rotary system that rests on the pellets and rotates slowly during the suction of the pellets. In some systems, the transport air is returned to the silo.

Specifications

Since these silos are air tight, the inblow air should be sucked out by a ventilator with a filter bag during the delivery of pellets. If the manufacturer of the silo has not equipped the silo with a 230V power outlet, than it should be done by the installer.



Plate 6: Below-ground silo made of concrete, discharge from above

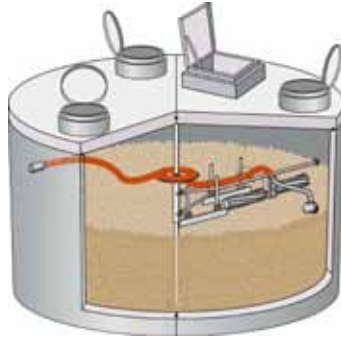

Plate 7: Large below-ground silo up to 60 m³



Plate 8: Below-ground silo made from synthetic materials, discharge from below

6.3 EXAMPLES OF STORAGE SYSTEMS

Nr	Type	Name	Charging	Extraction location	Material	Frame	Location	Exhaust	Extraction method	Comments
1	Fabric silo	Conical silo	Funnel/conus	From beneath	Fabric	Metal/wood	Above ground	Depends on material and manufacturer	Screw conveyor or suction (also combination)	
2	Fabric silo	Trough silo	Inclined bottom	From beneath	Fabric	Metal	Above ground	Depends on material and manufacturer	Screw conveyor or suction (also combination)	
3	Fabric silo	Flat silo	None	From top	Fabric	Metal/wood	Above ground	Depends on material and manufacturer	Screw conveyor or suction (also combination)	
4	Fabric silo	Elevating silo	Funnel/conus	From beneath	Fabric/plastic	Metal	Above ground	Required	Screw conveyor or suction (also combination)	Should not be combined with a screw conveyor. Extraction at bottom is after filling not possible in a period
5	Fabric/metal	Conical silo	Funnel/conus of metal	From beneath	Fabric/metal	Metal	Above ground	Required	Screw conveyor or suction (also combination)	
6	Metal silo	Trough silo	Inclined bottom	From beneath	Metal	Metal	Above ground	Required	Screw conveyor or suction (also combination)	Can be changed by size by adding elements
7	Plastic	Funnel/conical	Funnel/conus	Near bottom	PVC/HDPE/glassfiber	Not required	Above or below ground	Required	Suction	Manhole pit to be permanently sealed. If needed make passable for vehicles
8	Plastic	Spherical silo	Half sphere	Near bottom	Glassfiber	Not required	Below ground	Required	Suction	Manhole pit to be permanently sealed. If needed make passable for vehicles
9	Concrete	Spherical silo	Half sphere	From top	Concrete	Not required	Below ground	Required	Suction	Manhole pit to be permanently sealed. If needed make passable for vehicles

7. HOMEMADE PELLET STORAGE

The construction of a homemade pellet storage system needs careful planning and skilled building. Since large weights are stored, one should proceed with great care and be safety conscious. Usually pellets are stored in a basement room. The following instructions are based on this assumption. Of course other premises can be used, such as garages, or lofts. The modification of an existing oil tank is in exceptional cases possible, but is discouraged.

One should consider if building or other regulations permit the use of the room for storage purposes. Also proper filling and discharge should be assured. The storage room should be closed-off from the rest of the building to avoid dust infiltration to adjoining rooms during blowing-in and the use of the system. All seams and connections should be sealed carefully. Crossing the storage room with supply lines or air ducts should be avoided. If not avoidable, then the lines should be carefully sealed and protected. If the walls are damp, all contact with them should be prevented, so that the silo can have a surrounding air flow, in order to prevent condensation that could influence the quality of the pellets.

During construction, the static loads on both the floor and the adjoining walls (in so far the construction is leaning against the walls) need to be considered. In some cases it may be necessary to consult a building engineer or architect. The inblow and discharge facilities should be professionally earthed to prevent the build-up of an electrostatic charge.

7.1 THE SIZE OF THE STORAGE ROOM

In practice a rectangular room has been shown to be the most useful. The inblow and exhaust connections should preferably be placed at the short side of the silo. If the connections have to be made at the long side it can be useful to place two or more inblow pipes next to the exhaust pipe in order to utilize the full size of the silo. The connections should be easily accessible. The size of the storage room depends on the heat load of the building. The storage silo should not exceed twice the annual fuel consumption. The following examples show assumptions and calculations that can be used to estimate the required storage volume.

7.1.1 PELLET SILO WITH AN INCLINED BOTTOM

Assumptions

- Per 1 kW heating load = 0.5 m³ storage space (including the empty space under the inclined bottom)
- Useful storage space = 2/3 of overall storage space (including empty space)
- 1 m³ pellets = 650 kg
- Energy content ~ 4.8 kWh/kg (~ 0.5 l oil)

Example

- A family residence with a boiler capacity of 15 kW
- 15 kW boiler capacity x 0.5 m³/kW = 7.5 m³ storage volume required (including empty space)
- Useful storage space = 7.5 m³ x 2/3 = 5 m³

7.2 PROTECTION FROM MOISTURE AND WATER

Pellets are hygroscopic; in contact with water, damp walls or floors, they swell up and become useless. Damp pellets fall apart and can also block transport lines and damage walls. Please consider the following:

- The pellet store should be dry the year around. Especially in newly-built houses one should pay attention that the store room has dried.
- Normal air moisture content, such occurs under varying weather conditions, does not damage pellets.

If there is a risk of damp walls (even if only temporary) one should use purpose-built silos, such as ones made of fabric or one should construct appropriate protection against moisture (such as airspace between wall and silo).

7.3 STATIC PRESSURE

The enclosing walls should be able to resist static pressure imposed by the weight of the pellets (bulk density of ~650 kg/m³) as well as the extra pressure during inblowing and associated pressure peaks. The silo walls as well as their fixing to the floor and the ceiling should be professionally and properly constructed according to construction rules.

7.4 GROUND PLAN OF A PELLET STORE

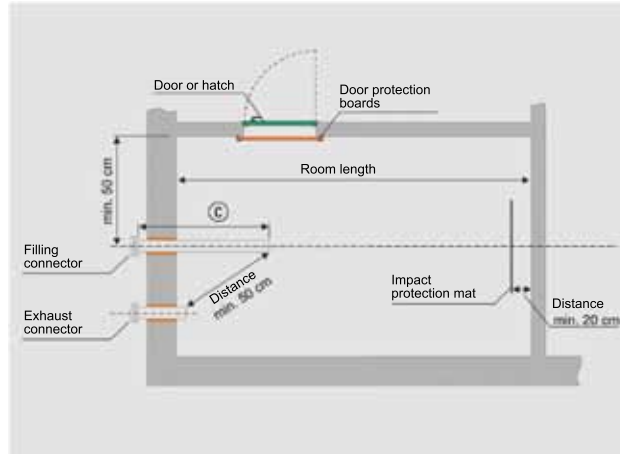

Plate 9

C

Room length with a height up to 3 m = 0.5 m

Room length with a height of 3-5 m = 1 m

The roof and walls of the silo should be made of a material such that the pellets are not damaged or contaminated by abrasion, contact or flaking.

During the filling operation over- and under-pressure can occur in the silo. The silo must be constructed in such a way that it can withstand the weight load of the pellets plus the momentary load presented by pressure changes (up to ca 0.2 bar) during filling. One should not include windows with glass panes. All connections to existing walls, in corners and along walls should be constructed in a dust-proof manner. In the construction of large silos one should always consult a structural engineer for static pressure calculations as well as fire protection. In the practice the following wall thicknesses have proven themselves:

- Reinforced concrete, 10 cm
- Bricks, 17.5 cm laid in bonded courses and plastered on both sides. The corners should be reinforced and connected to the floor
- Wood construction: 12 cm beams with a spacing of 62 cm between beams, covered on both sides with three layered panels or multiple-layer plywood, connected to floor, ceiling and walls.

7.5 CROSS SECTION OF A SILO WITH INCLINED BOTTOM

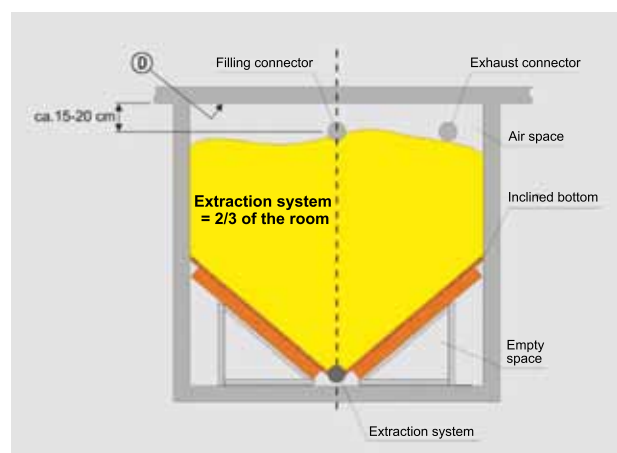

Plate10

D

A smooth wall surface reduces damage to pellets during blowing in.

Tip

When using screw conveyor or pneumatic discharge systems, empty the silo as much as possible.

7.6 CONSTRUCTION RECOMMENDATIONS FOR THE INCLINED BOTTOM SOLUTION

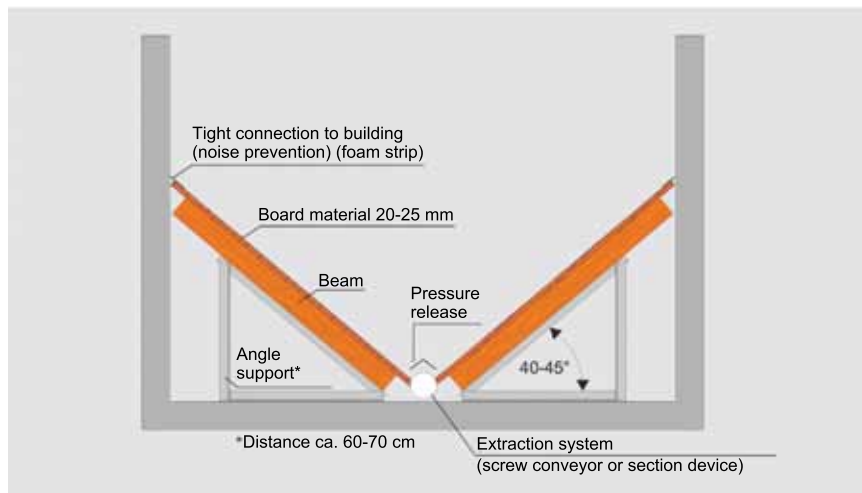

Plate 11

The inclined bottom of the pellet silo lets the pellets slide to the discharge opening (for example screw conveyor or suction head). The bottoms should be constructed in such a way that the silo is emptied as completely as possible (Plate 11). The angle of the inclined bottoms should be at least 40°, but better 45°, so that the pellets can discharge by themselves. If the inclination is less than 40°, the pellets will not discharge as easily and this may lead to bridging of the fuel.

The inclined bottom should preferably be made of wooden sheet material with as smooth a surface as possible. Three layered panels or multiple-layer plywood has been used successfully.

So pellets can reach the discharge area unhindered, edges, steps and flat areas around the screw conveyor should be avoided.

The inclined bottoms should be connected to the surrounding walls in such a way that pellets cannot fall into the empty space below the bottom.

The inclined bottoms should be able to withstand the weight load of the pellets (bulk density 650 kg/m³). A stable framework is necessary.

Next to stable planks, one can find purpose-built angle irons that will ease the construction of the inclined bottom considerably. The supports should be at a maximum distance of 60-70 cm apart.

The connection to the discharge system should be constructed according to the manufacturer's or supplier's instructions. Manufacturers also offer purpose-built cone constructions that will ease the work.

To prevent noise from being transferred to the building, the construction of the inclined bottoms of the discharge system (for example screw conveyors or suction heads), as well as any passage of walls should be made in such a way that sound is not transferred (Plate 12). For fire protection see Chapter 10.

The pressure release angle of the screw conveyor system should show a slit of six to seven centimetres. If the slit is wider, perpendicular forces will lead to an increased load on the screw and may increase the rate of malfunction.

7.7 CROSS SECTION OF A PELLET SILO

7.7.1 ROOM LENGTH LESS THAN 2 M

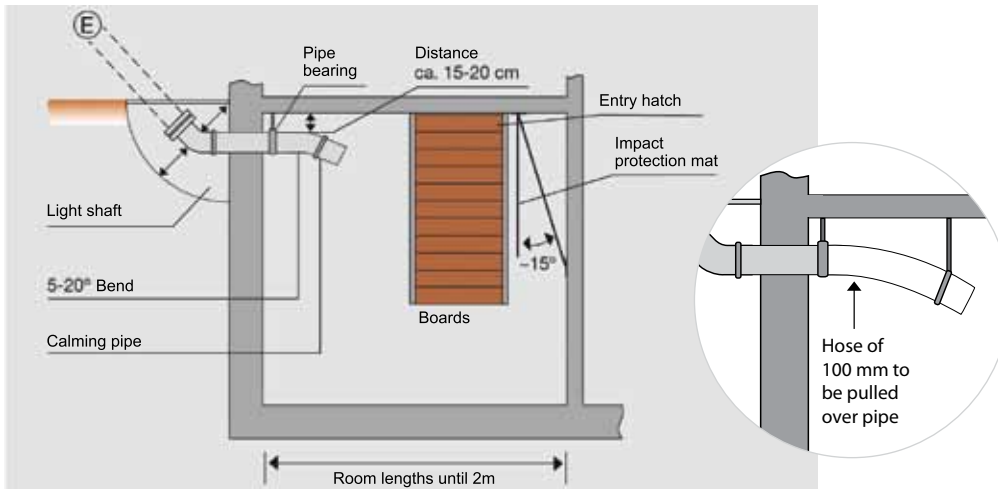

Plate 12

E

If the connector ends in a light shaft, it should be possible to connect the filling hose to a straight section. A free space of at least 35-40 cm should be kept around the connectors.

Plate 12a

Alternative construction

In small pellet silos under 2 m in length one should insert a bent pipe at a 15-20 degree angle at the end of the inblow pipe, pointing downwards. This directs the stream of pellets slightly downwards. After this bend a straight pipe of minimum 30 cm should be attached to slow down the flow of the pellets. In place of a bent pipe followed by a straight stretch, one can also install a piece of spiral inblow hose (PVC hose with embedded steel spiral), which is fixed in place with pipe brackets and which bends slightly downwards (Plate 12a).

The combination of the 15-20 degree bend and the slightly inclined impact protection mat will direct the pellets downwards. In practice it is thus possible to blow the pellets more gently into the silo, reducing the risk of breakage and as such the amount of fines.

7.7.2 ROOM LENGTHS FROM 2-5 M

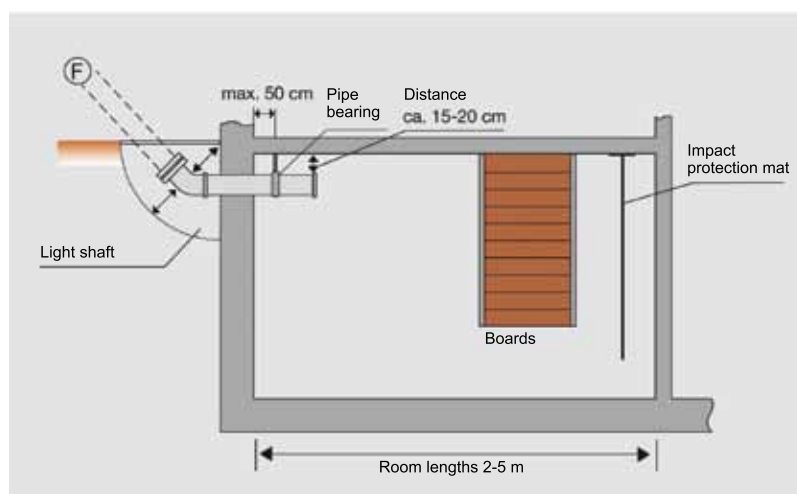

Plate 13

F

If the connector ends in a light shaft, it should be possible to connect the filling hose to a straight section. A free space of at least 35-40 cm should be kept around the connector.

The filling pipe should have a distance of 15-20 cm from the ceiling of the silo, so that the pellets do not hit the ceiling when they are blown in.

The impact protection mat on the opposite side of the silo should be at a distance of between 20-30 cm from the rear wall and be attached to the ceiling.

The exhaust connector should be mounted at least 0.5 m, preferably further, away from the inblow connector. Both the lid and the pipe should be clearly marked as such.

7.7.3 ROOM LENGTHS GREATER THAN 5 M

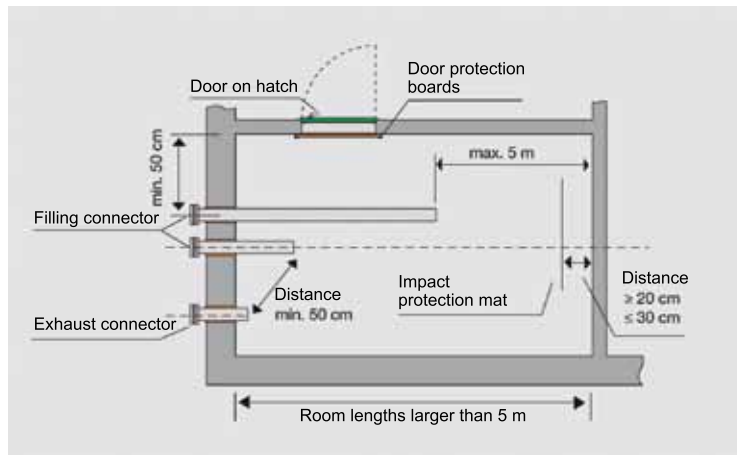

Plate 14

If the pellet silo is longer than 5 m it is recommended to use a second, longer filling pipe.

The filling pipes should have a distance of 15-20 cm from the ceiling of the silo, so that the pellets do not hit the ceiling when they are blown in.

The impact protection mat on the opposite side of the silo should be at a distance of between 20-30 cm from the rear wall and be attached to the ceiling. If necessary a second impact protection mat should be installed.

The silo can now be filled from the rear to the front by the long filling pipe. In the second stage the remainder of the silo can be filled using the short filling pipe. The connectors to these pipes should be clearly marked long and short filling pipe.

7.8 FUNCTION OF THE IMPACT PROTECTION MAT

The installation of an abrasion and tear-proof impact protection mat is absolutely necessary. It should be placed at right angles to the incoming stream of pellets near the opposite wall of the silo from the inblow pipe. According to the size and shape of the silo, one should, during the first filling of the silo, test if the impact protection mat fulfils its function (the incoming stream of pellets must hit the mat). If there is more than one filling pipe, it may be necessary to install more than one impact protection mat.

The task of the impact protection mat is to prevent pellets from hitting the enclosing walls, which might destroy them. On top of that, the wall itself – especially during the start of the filling operation – is protected against damage. Screws are used in such a way that they do not damage the pellets

Recommended mat material and size

HDPE-film with a thickness of at least 2 mm or abrasion-proof rubber with a thickness of 1-3 mm. Carpet rests or weaker plastic or rubber materials are unsuitable and can cause considerable damage if the fibres or rubber parts enter the screw conveyor.

The impact protection mat must be sufficiently large (ca. 1.5x1.5 m) so that the full stream of pellets can be caught. Normally the mat is hanging free from the ceiling (exception is very small silos, see chapter 7.7.1). The length of the mat should be such that the stream of pellets does not come under it or pushes it aside.

7.9 DOORS, WINDOWS AND HATCHES

Doors and hatches should be constructed in a manner that prevents dust from entering the rest of the building. Doors, windows and hatches should open outwards and have a dust-proof seal all the way around. Windows are usually already sealed by the manufacturer and have to be approved for the application (safety glass, since pressure spikes may occur). On the inside of the door frame, wooden battens should be placed to release the pressure on the door. Locks should be dust-proof sealed from the inside, this allows access to the silo room at all times.

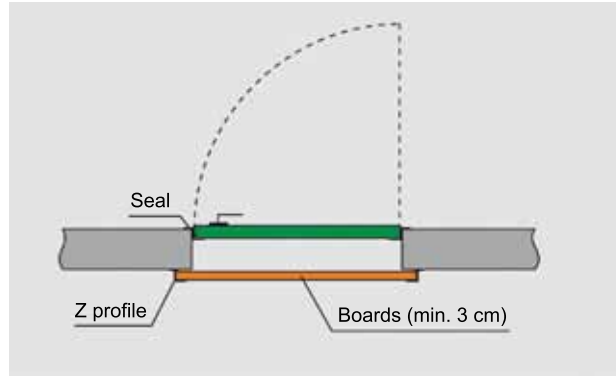

Plate 15 Mounting for pressure release

An optical filling level control method is recommended (such as small peep holes in the wooden planks). If clear plastic (Plexiglas) is used for the optical level control, then these windows can accumulate fines, attracted by static electricity. The level of fines on the plastic viewer fines is not a reliable indicator of the total amount in the silo.

If possible, the door leading into the silo should be in the vicinity of the inblow pipe. Otherwise there is a risk that access will be blocked, since pellets heap up at side of the store opposite the inblow pipe. In all cases the door should not be situated behind the impact protection mat.

The pellet supplier is not liable for damage or contamination that may occur if sealing of doors and windows in the storage room is not properly done. Access should be of such a size to allow easy entry. The pellet silo must be accessible to the supplier to check the filling level prior to the filling operation.

7.10 INSTALLATIONS IN THE STORAGE ROOM

If there are existing installations in the silo room (such as piping, sewage pipes etc.) that cannot be removed without considerable effort and they cross the flight path of the incoming pellets, then these installations should be protected so that they deflect the pellets and do not get damaged (for example by sheet metal or wooden encasing, in a way that avoids damage to pellets during inblow).

Electrical installations such as switches, sockets, lights, junction boxes should not be located in the storage room. Explosion-proof installations can be exempted from this rule, as well as extraction systems that have been especially constructed for that purpose.

7.11 THE FILLING SYSTEM

7.11.1 INBLOW AND EXHAUST PIPES

Any storage facility for pellets should have an inblow connector (more than one is possible) and an exhaust ventilation connector of metal and their purpose should be clearly and permanently marked on piping and lids.

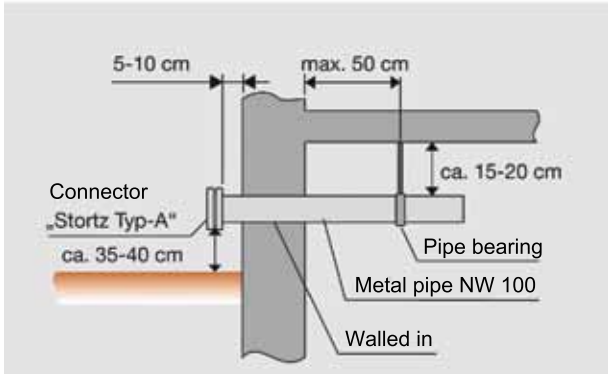

Plate 16.1 Inblow and exhaust pipes without light shaft

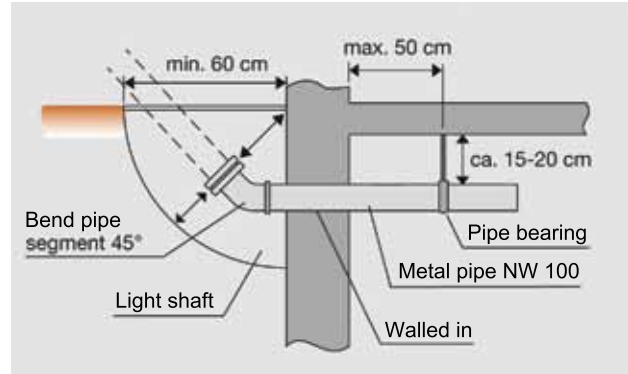

Plate 16.2 Inblow and exhaust pipes with light shaft



Plate 17 Ventilation cap of plastic



Plate 18 Ventilation cap of stainless steel



Plate 19 Exhaust ventilator

Usually connectors of the type Storz Type-A, with 100 mm inside diameter are used on delivery trucks. The connectors should be mounted about 15-20 cm below the ceiling of the silo, measured from the topside of the pipe to the underside of the ceiling. After a maximum of 50 cm, a pipe bracket should be mounted to fix the pipes in place. If the connector ends in a light shaft, it should be possible to connect the filling hose to a straight section sticking out of the shaft. The connectors should be solidly fixed in place, so that they cannot turn or twist when the connector of the filling truck is attached or that the position of the filling pipe is changed (Plate 16.1)

7.11.2 DESIGN OF THE FILLING SYSTEM

Bends in piping lower the quality of the pellets and increase the amount of fines. During planning one should consider if it is possible to avoid bends or at least reduce the number to an absolute minimum.

Internal filling pipes should preferably be short (not longer than 10 m) and have few changes of direction. If the change of direction is more than 45 degrees, only bends with a radius of more than 200 mm should be used.

Only pressure-resistant metal pipes should be used for the filling system. Plastic pipes should never be used, since these can become electrostatically charged and release sparks during the filling operation.

The filling system should be earthed to safeguard against electrostatic charges. The filling pipes may otherwise become electrostatically charged during the filling operation. To avoid this, the piping should be earthed with a wire of at least 4 mm² or a potential equalization bar.

Pipes and bends should have a smooth inner surface, so that the pellets are not damaged during blow in. No rivets or screws should extend into the pipe. If the piping has been welded check that no drops or ripples are formed on the inside of the pipes at the welding seams. Piping made of steel, should only be cut with a pipe cutter, so that the edges remain smooth.

The filling pipe should not end in a bend. After a bend a straight piece of piping of at least 30-50 cm should be attached to slow down the pellets.

Filling connectors should be professionally connected (by an electrician) using a 4 mm² wire to a potential equalization bar. The connection to earth is important and necessary to discharge possible electrostatic charge during the filling operation.

The ends of the connecting pipes should be closed with special lids that permit an exchange of air between the silo and the outside. This prevents emissions and odours from the pellets.

The connector and the pipe diameter of the exhaust pipe should have the same dimensions as the inblow connector.

After the filling operation the connectors should be closed using the lids. The lids should allow air exchange between the silo and the outside.

The filling connectors can be equipped with a lock if this is deemed necessary. The keys should be available to the supplier.

The exhaust ventilator needs a power socket (230V, 16A). It should be placed in the vicinity of the exhaust connector or made accessible to the pellet supplier. Inblow and exhaust connectors should be clearly marked as such.

One should never change between inblow and exhaust connectors as an overpressure might be created in the silo, as pellets could be situated in front of the exhaust pipe.

During winter one should take care that access to the connectors and their surroundings (lids of light shafts) is free of snow and ice on the day of delivery.

Around the connectors, also when they are situated in a light shaft, a working area of 35-40 cm around the connectors should be available.

7.12 SPECIAL SOLUTIONS FOR THE FILLING SYSTEM

If a standard solution is not possible because of special local circumstances, a special solution can be designed by professional companies.

In principle, pellets have a angle of repose of 45-60°, similar to many other bulk materials. In wide storage silos it is therefore recommended to install several inblow pipes at a spacing of 1.5 m. If the geometry of the silo is unfavourable it is possible that the filling density will be less than 650 kg/m³.

The special solutions shown are not optimal. Long filling pipes and bends will increase wear on pellets. The silo cannot always be filled optimally.

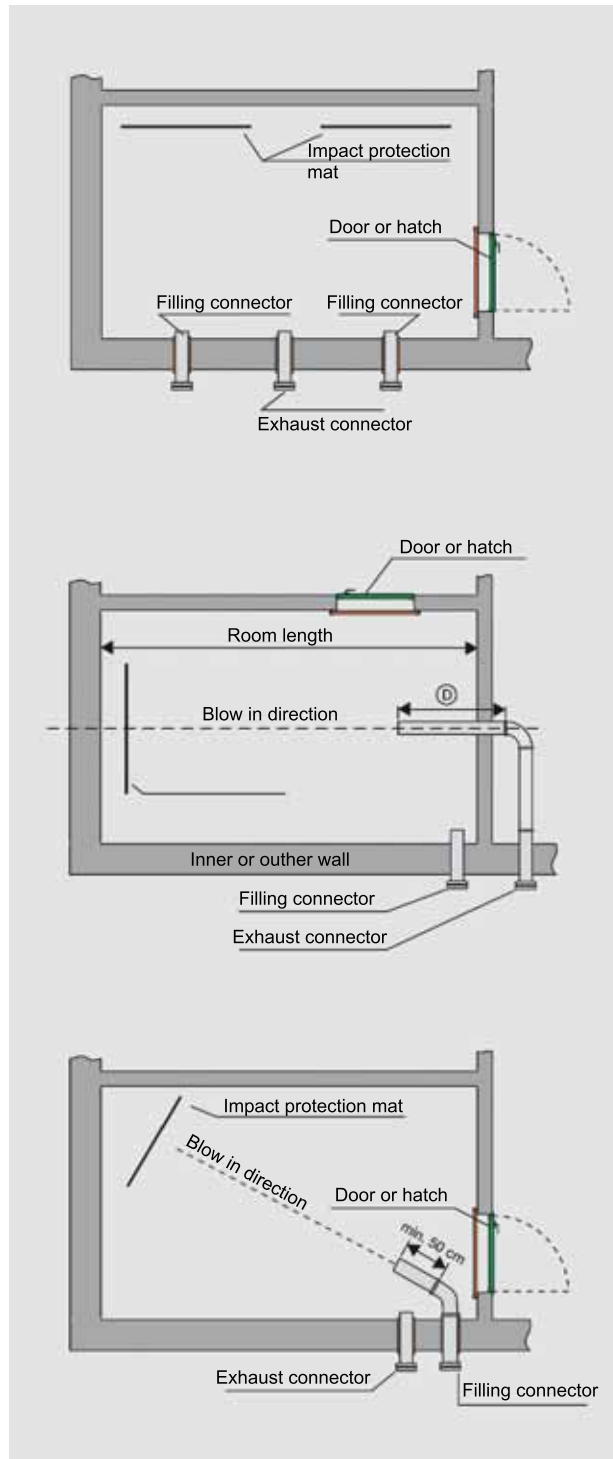

Plate 20 Special solutions for the filling system

8. CONSTRUCTION EXAMPLES OF PELLET SILOS

8.1 PELLET SILO WITH INCLINED BOTTOM AND SCREW CONVEYOR

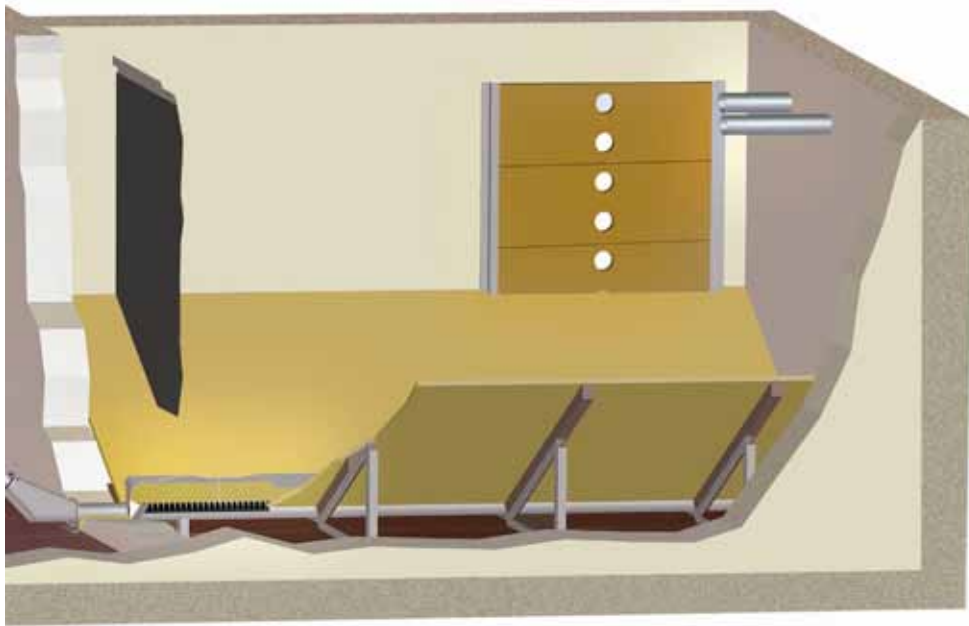

Plate 21

8.2 PELLET SILO WITH INCLINED BOTTOM AND SUCTION EXTRACTION



Plate 22

8.3 PELLET SILO WITHOUT INCLINED BOTTOM AND SCREW CONVEYOR



Plate 23

8.4 PELLET SILO WITHOUT INCLINED BOTTOM AND SUCTION EXTRACTION

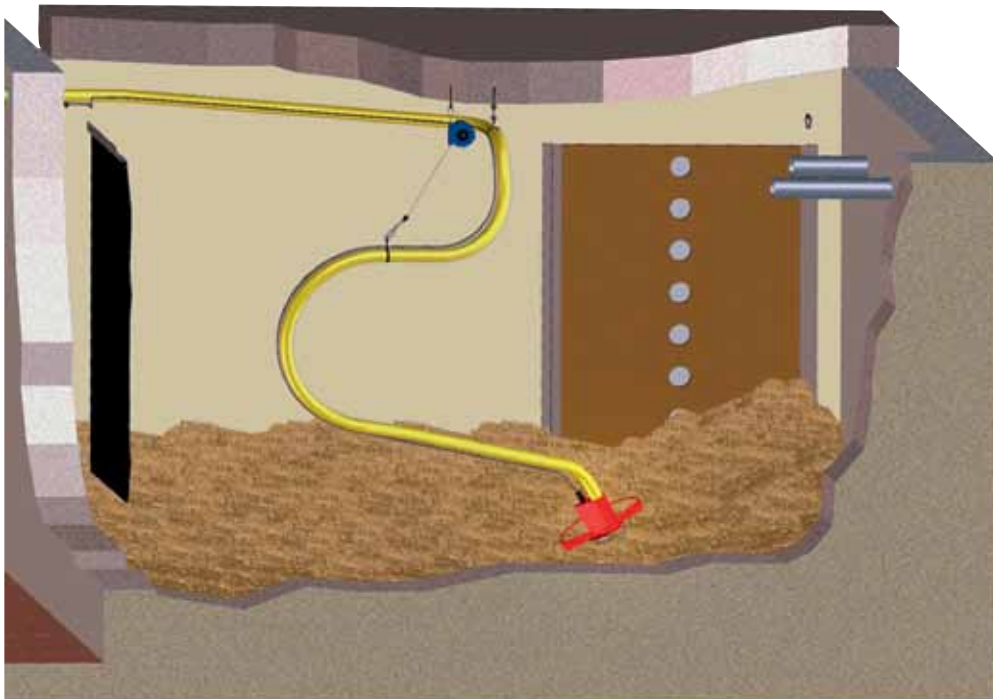

Plate 24

9. MEASURING SYSTEMS FOR PELLET SILOS

Systems to check the filling level of pellet silos are not yet common, but are receiving increased attention because of increasing levels of cost assessment and control. Especially in a large volume silo, assessment of filling level can save money by buying pellets when the price is low. Manual checking is no longer necessary and thus running costs are lowered, especially in heat contracting. Some applications offer control in real time, others transmit the data intermittently. Systems exist that transmit data on the filling status during the filling operation or that inform the operator of the pellet heating system currently about the actual filling status. All systems should be either explosion-proof or at least be classified as damage-proof.

9.1 SILO FILL LEVEL

By measuring the electric field between two parallel probes in the silo one can measure the filling level of the silo. Usually probes consist of steel wires, metal pipes or metal strips. An accurate control is thus possible and offers the operator the advantages referred to previously. The measuring systems can relay, via remote control by SMS or by telephone contact, the actual filling situation in real time. Different measuring systems are available for large silos or silos made of fabric, as either filling status indicator or an alarm.

9.2 FILLING STATUS WITH PRESSURE SENSORS

Pressure sensors that are situated either on the inclined bottom or at the filling connector are the heart of this system. If several sensors are applied then a differentiated filling status can be shown. The pressure sensor at the filling connector can give the pellet supplier a signal when the silo is full and the filling operation can be stopped. This signal can either be given by a LED beside the filling connector and/or by an acoustic signal. Systems to avoid overloading the pellet silo and the filling pipe are based on a similar principle.



Plate 25 Pressure sensor for the filling status in an inclined bottom

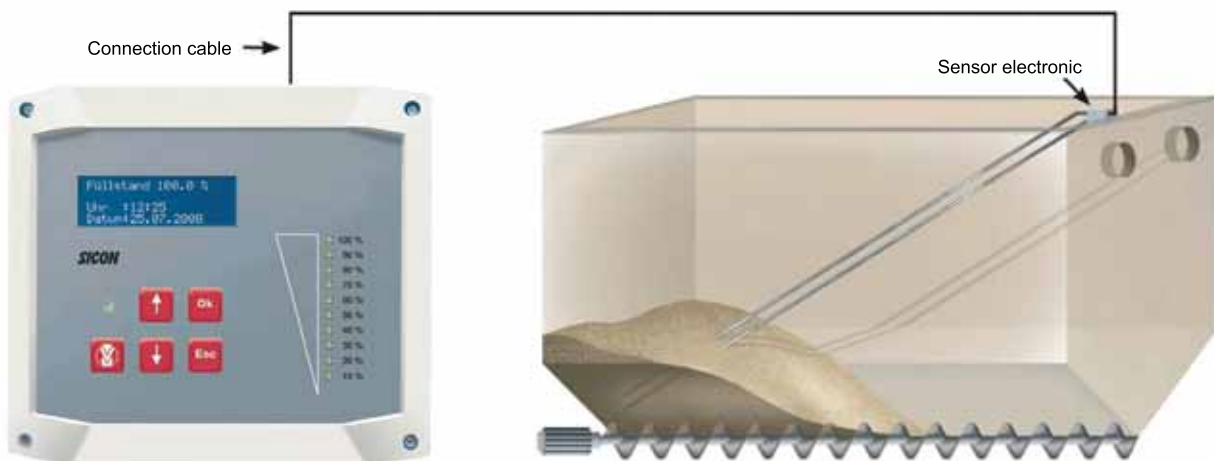

Plate 26 Capacitive filling status control in an inclined bottom silo

10. FIRE PROTECTION MEASURES AT THE SILO

Small buildings for storing wood pellets are exempt from the building regulations provided they are detached from the main building. However, the storage facility should be a minimum of 2m from the main building and space separation requirements given in Technical Guidance Document B (Fire Safety) may apply.

The space separation rules (that is the distance between the storage facility and the main building) are related to the unprotected area of the wall of the building facing the store and the distance of that wall to the relevant boundary (an imaginary line usually will be half way between the store and the main building). An unprotected area is an area of a wall with a lower fire resistance than that required by TGD B and this area would include window and doors. Essentially the greater the unprotected area of the wall, the greater the distance to the relevant boundary and by implication the store. It is not possible to give definite guidance in this area in this document and TGD B should be consulted.

If the pellets are stored within a building, in a basement for example then the Building Regulations apply and TGD B should be consulted for advice. Storage falls under Purpose Group 7(a) and the fire resistance of this Purpose Group is given in Table A2 of TGD B and summarised below:

Purpose Group 7(a)	Basement depth		Height to top storey		
	>10m	<10m	<=5m	<=20m	<=30m
Non-sprinklered	120	90	60	90	120
Sprinklered	90	60	30*	60	90

Basement depth is to lowest point.

* The minimum fire resistance for compartment walls or floors is 60 minutes.

It is likely that the intermediate floor and possibly wall between the storage facility and the rest of the building would be treated as a compartment floor or wall to avoid having the whole building designated as Purpose Group 7a. In addition stairs within the building and leading to the store would have to be a protected shaft or stairway. The performance requirement of fire doors is given in Table B1 of TGD B and in some instances may have to be high performance doors depending on the fire resistance of the compartment.

Given the complexity of TGD B it is recommended that a fire expert be consulted for advice where wood pellets are stored within a building.

FIRE PROTECTION REQUIREMENTS FOR A PELLET STORAGE FACILITY

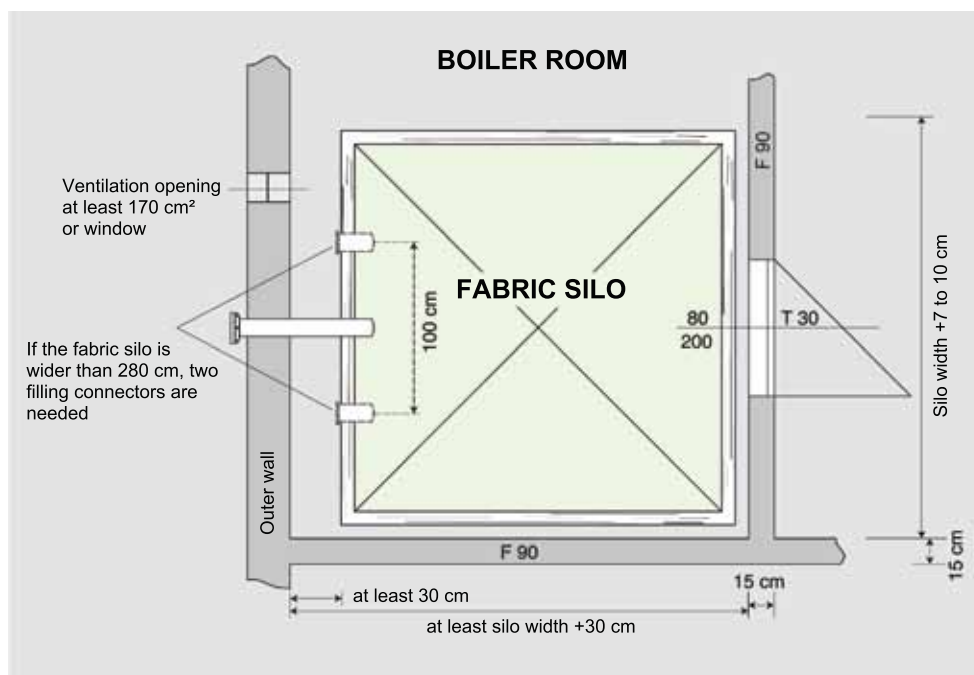

Plate 27 Ground plan of a pellet store with purpose-built fabric silo

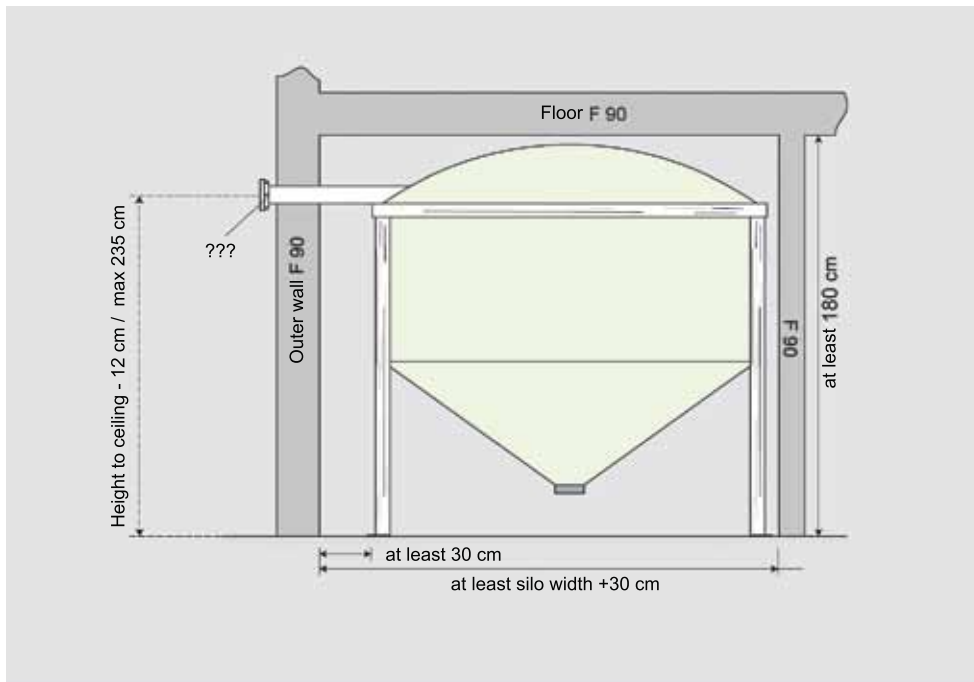

Plate 28 Cross section of a storage room with purpose-built fabric silo

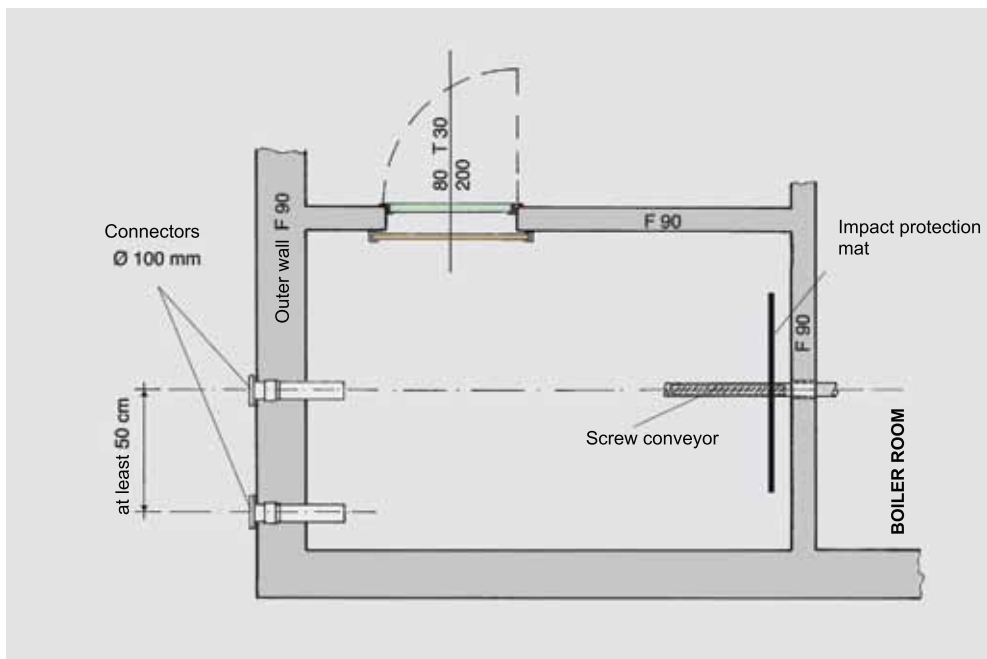

Plate 29 Ground plan of pellet storage room with homemade silo



G

Detail of wall crossing

When crossing a firewall with screw conveyors in steel pipes, the rockwool should extend 30 cm on either side of the wall. If plastic pipes are used a fire protection sleeve is necessary.

Plate 30 Cross section of pellet storage room with homemade silo

11. ANNEX

SAFETY RECOMMENDATIONS FOR PELLET STORAGE FACILITIES

The HSE issued a safety notice regarding wood pellet storage in November 2012 – the reference is OPSTD 3-2012

The HSE is advising all those who use, install, maintain or distribute wood pellet boilers and/or manufacture/store/distribute wood pellets to consider the following:

- Wood pellet hoppers/tanks/storage rooms and boilers should always be installed and commissioned by a competent person, normally approved by the manufacturer/supplier. This is particularly important if the installation involves the replacement of a coal-fired boiler, where existing boiler room and storerooms are often utilised.
- Do not enter the pellet storage area or place your head into a wood pellet hopper as they can contain toxic gases. No personnel should enter the hopper/tank unless fully trained and competent in confined space entry procedures. Controls should be put in place to ensure safe entry as per the HSE's Code of Practice for Working in Confined Spaces. This should include adequately ventilating the storage area and checking carbon monoxide and oxygen levels with an appropriate device prior to entry. It is recommended that the store room is ventilated at all times, either mechanically or by being designed to have a through draft.
- Ensure that the boiler and pellet feed mechanism etc. is cleaned and serviced by a competent person as specified by the manufacturers' instructions.
- If any problems are encountered with the unit, such as the system not heating correctly or flue gas is flowing into the boiler room, turn the unit off and contact the supplier and/or manufacturer and request assistance.
- Duty holders who store wood pellets, particularly in bulk should have a suitable risk assessment and safe system of work in place.
- Manufacturers, suppliers and distributors of wood pellets should provide adequate health and safety information to the user in their materials safety data sheet
- Warning signs should be placed on the pellet storage area access door, ideally on both sides so it can be seen when the door is open. The warning sign should include the following information:
 - o DANGER - RISK OF CARBON MONOXIDE POISONING -There is a danger to life from odourless carbon monoxide and lack of oxygen. Check atmosphere before entry with an appropriate device. No entry for unauthorised persons. Keep children away from the storeroom.
 - o No smoking, fires or naked flames.
 - o The room should be adequately ventilated before entering. Keep the door open whilst inside
 - o There is a danger of injury from movable parts.
 - o Filling procedures should be carried out accordance to the heating installation company and the pellet suppliers



CAUTION - RISK OF CARBON MONOXIDE POISONING



WOOD PELLET STORAGE ADVICE & RECOMMENDATIONS:

- There is a danger to life from odourless carbon monoxide and lack of oxygen.
- Check the atmosphere with an appropriate device before entry into the pellet store
- No entry for unauthorised persons. Keep children away from the storeroom.
- No smoking, fires or naked flames.
- The room should be adequately ventilated before entering. Keep the door open whilst inside.
- There is a danger of injury from movable parts.
- Pellet filling procedures should be carried out accordance to the instructions of the heating installation company and the pellet supplier.

UK Pellet Council
C/O Renewable Energy Association
2nd Floor
25 Eccleston Place
Victoria
London
SW1W 9NF